



SonFlow

Instruction Manual

Plate Heat Exchanger



Foreword

The information presented in this instruction manual has been compiled to provide the operator with a thorough understanding of the capabilities and operation of the unit. Read this manual thoroughly and understand the precautions regarding the safety of the equipment and its functions before handling the equipment.

Should a malfunction occur, please consult a SonFlow representative.

Introduction

This instruction manual provides information and operating instructions explaining design, function, operation and carry out maintenance of gasketed plate and frame heat exchanger.

The plate heat exchanger performs heat exchanging by transferring heat between hot and cold fluids flowing alternately through heat transfer plates, which are thin metal sheets having fine corrugated patterns.

The heat exchanger shall only be operated by persons who have knowledge of the process. Installation and maintenance must only be performed by persons who have knowledge and authorization according to local regulations.

At the end of use, the equipment must be disposed, according to relevant local regulations. Besides the equipment itself, any hazardous residues from the process liquid must be considered and dealt with adequately.

Safety

The heat exchanger shall be used and maintained in accordance with this instruction manual. Incorrect handling may result in serious consequences with body injuries or property damage. In such cases, SonFlow must be indemnified.

The heat exchanger should only be used in accordance with the specified configuration of material, media types, temperatures and pressure.

Published by

SonFlow A/S

Nordager 25
DK – 6000 Kolding
+45 8657 1344
info@sonflow.dk

© SonFlow A/S 2022

Copyright

This document and its contents are subject to copyrights and other intellectual property rights owned by SonFlow A/S. No part of this document may be copied, re-produced or transmitted in any form or by any means, or for any purpose, without SonFlow's prior express written permission. Information and services provided in this document are made as a benefit and service to the user, and no representations or warranties are made about the accuracy or suitability of this information and these services for any purpose. All rights are reserved.

Table of Contents

1. General	4
1.1 Nameplate for SonFlow heat exchanger	4
1.2 Correct operation	4
1.3 Precautions	5
1.4 Thermal design	5
2. Construction	6
2.1 Frame	6
2.2 Plates	7
2.3 Gaskets	7
2.4 Plate types	7
2.5 Start plate	8
2.6 Plate function	8
2.7 Flow arrangement	8
2.8 Pressure drop	9
2.9 Heat transfer problems	9
2.10 Removal of plates	10
2.11 Replacing plates	10
2.12 Cleaning of plates	10
3. Installation	12
3.1 Lifting	12
3.2 Raising	13
3.3 Connections	15
3.4 Installing the pipe connections	15
3.5 Storage	15
3.6 Start-up	15
4. Commissioning	16
4.1 Operation	16
4.2 Shut down for a short period	17
4.3 Shut down for a long period	17
5. Maintenance	18
5.1 Frame maintenance	18
5.2 Pressure test after maintenance	18
6. Problem solving	19
7. After-sales & service	19

1. General

1.1 Nameplate for SonFlow heat exchanger

The nameplate gives important information about the design of the heat exchanger. This information is related to the design and approval of the heat exchanger. The values on the nameplate may not be exceeded.

This plate is fitted on the plate heat exchanger and provides information about:

- Heat exchanger type
- Manufacture number
- Allowable pressures
- Test pressures
- Allowable temperatures
- Volume
- Year of construction
- Tensioning dimensions
- Differential pressure

Each heat exchanger is delivered with a dimension drawing and a circuit diagram.

- The dimension drawing includes outer dimensions as well as the type, size and position of the piping connections.
- The circuit diagram shows the specific arrangement of the plates, their type, alloyed steel, thickness and gasket material.

1.2 Correct operation

This instructional manual provides the necessary information for correct and safe operation to avoid accidents or incorrect use. Always follow the instructions and safety regulations.

If a problem occurs with your SonFlow heat exchanger, please contact a SonFlow representative – all indistinctions must be solved to avoid injuries and damages. SonFlow will not accept responsibility for any damage or injury resulting from not following the instructions in this manual.

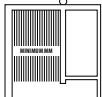
	
TYPE: <input type="text"/>	YEAR: <input type="text"/>
MANUFACTURER NO.: <input type="text"/>	MARKING: <input type="text"/>
ASSEMBLING MEASURE MIN.: <input type="text"/>	MM: <input type="text"/>
MAX. DIFFERENTIAL PRESSURE: <input type="text"/>	BAR: <input type="text"/>
PS. MAX WORKING PRESSURE BAR: <input type="text"/>	PT. MAX TEST PRESSURE BAR: <input type="text"/>
PRODUCT/MEDIUM: <input type="text"/>	
FLUID: <input type="text"/>	V. VOLUMEN IN LTR.: <input type="text"/>
TS. MIN WORKING TEMPERATURE: <input type="text"/>	TS. WORKING TEMP. MAX °C: <input type="text"/>
	IMPORTANT: 1) The Plate heat exchanger must not be assembled under the stated minimum assembling measure. Please contact SonFlow distributor if the plate heat exchanger is leaking when tightened to the minimum measurement. 2) The starting up must be done without shocks and against closed valves.
SonFlow A/S Nordager 25 6000 Kolding Denmark Tel. +45 86 57 13 44 info@sonflow.dk www.sonflow.dk	

Example of CE metallic name plate

SonFlow heat exchangers are specifically designed and built for the operating conditions, therefore sudden changes should be prevented, as they can severely damage the heat exchanger. The heat exchanger should be used in accordance with the specified configuration of material, media types, temperatures and pressure for your specific customized heat exchanger.

If you wish to modify the design conditions, please contact a SonFlow representative – written approval by SonFlow are necessary. Always consult a SonFlow representative for advice on:

- New plate pack dimensions if you intend to change the thermal tasks
- Selection of gasket material if operating temperatures and pressures are permanently changed, or if another medium is to be processed in the heat exchanger.

1.3 Precautions

Please be aware of bodily injury and equipment damage.

Bodily injury:

- Burns as a result of touching the heat exchanger
- Release of pressurized media application
- Contact with chemicals
- Sharp edges

Damage to equipment:

- External forces
- Corrosion
- Chemical action
- Erosion
- Material exhaustion
- Water hammer (can appear during the start-up/shut down of a system or an off/on valve)
- Thermal/mechanical shock
- Freezing
- Transportation/lifting

The heat exchanger may only be used with the fluids specified on the nameplate and design sheets.

Start-up:

- Check the bolts are tight enough as they can loosen during transport.
- Check that there are no visible leakages from the plate pack, valves or piping system. A demountable heat exchanger can always leak, therefore, consider installing a drip tray underneath the heat exchanger.

If the heat exchanger's temperature is below the gasket's minimum temperature before installation and service, we recommend heating the heat exchanger above this limit to avoid cold leakage and deformed plates. Before pressurizing the heat exchanger, it is important to ensure that the temperature of the heat exchanger is within the temperature range as stated in the dimension drawing.

If the heat exchanger is shut down for several days or longer, it should be drained. Draining should also be done when the process is shut down and the ambient temperature is below the freezing temperature of the media. Depending on the media processed, it is recommended to rinse and dry the heat exchanger plates and connections (*described in section 4.2*).

1.4 Thermal design

SonFlow plate heat exchangers are designed and calculated according to the newest technology. In the design sheet, the nominal capacity and pressure losses are mentioned. If a performance test must be carried out, the exchanger must be clean.

2. Construction

The basic structure of a heat exchanger is shown below.
The specific execution depends on the application.

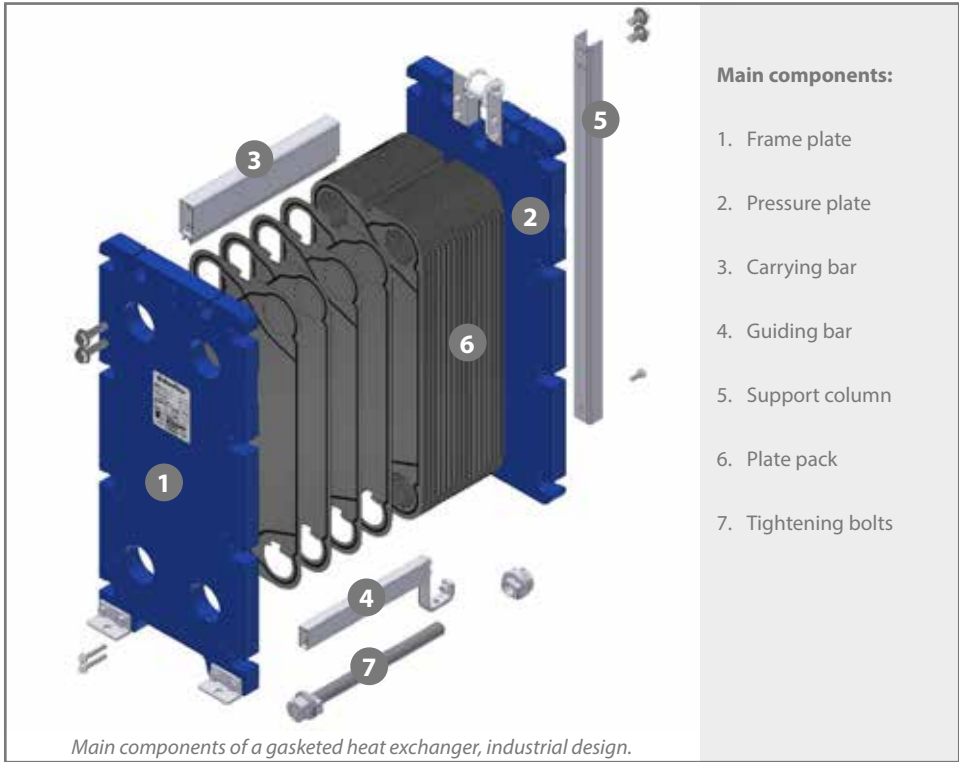

2.1 Frame

The heat exchanger consists of a frame plate (head), a pressure plate (moveable), a carrying bar, a guiding bar and a column. The tightening bolts are used to press the plate package together. The size and number depend on the heat exchanger type. There are different designs of the frame depending on the design pressure and the application of the heat exchanger.

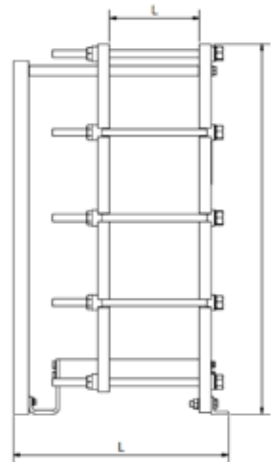

2.2 Plates

The number of plates is, as well as size and dimension, depending on the thermal output and flow rate required. The type of material depends on the media and their temperatures; please check the design sheet when ordering spare parts.

The plates can be made of a variety of materials, compatible with the process.

The material used:

- Stainless steel
- Titanium
- Nickel
- C276
- SMO254
- Other materials on request

2.3 Gaskets

The gaskets prevent intermixing of the media and can be supplied in different materials such as NBR, EPDM and Viton. The gasket material is specifically selected to be compatible with the medium processed. The click-on gasket is a "glueless" system for sealing - the gaskets are a single piece, molded construction, which fits into the continuous gasket groove in each plate. The "glueless" system is an easy and fast click-on installation without any glue or tools. The gasket is also simple to remove.



Click on



Hang on

Replacement of old

gaskets:

- Remove the plate from the frame
- Slowly pull the gasket away
- Clean and dry the gasket groove
- Position the new gasket on the plate for a proper groove fit
- Make sure that the tabs of the gasket are lined up with the slots
- Insert each tab inside its corresponding slot and push firmly until the tab locks into the slot

2.4 Plate types

The plate material is selected accordingly to the customer's requirements (e.g. pressure, temperature, media, operating mode).

The plates are available in several different designs:

- A herringbone pattern, to optimize performance, comes in a thermal short (TK) and a thermal long (TL) model, which can be mixed into a third variation - thermal mix (TM).
- A Free Flow model with wide channels suitable for difficult media containing solids or high viscous products.

All types of plates are designed to create the best possible heat transfer:



*Thermal short plate: short wide chevrons.
Provides a lower heat transfer and pressure drop*

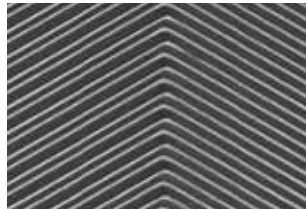

*Thermal long plate: tall skinny chevrons.
Provides a higher heat transfer and pressure drop*



Free Flow plate: wide channels, ideally suited for fibres, particles and high viscous products.

2.5 Startplate

Replace the start gaskets using two standard gaskets:

1. Cut two gaskets into half, and cut away the hang-on tab and the pieces between the rings. Discard the half without rings.
2. Apply a small amount of glue onto the gasket groove, on the marked area. (We recommend: Superglue klebfix 4-in-1 from Würth)
Be sure to apply glue only to the outside of the gasket groove at the porthole area.
If glue reaches the inside of the porthole, the start plate can leak.
3. Apply the two gasket halves with rings in the gasket track.



1) Cut two gaskets into half, and cut away the marked tabs.

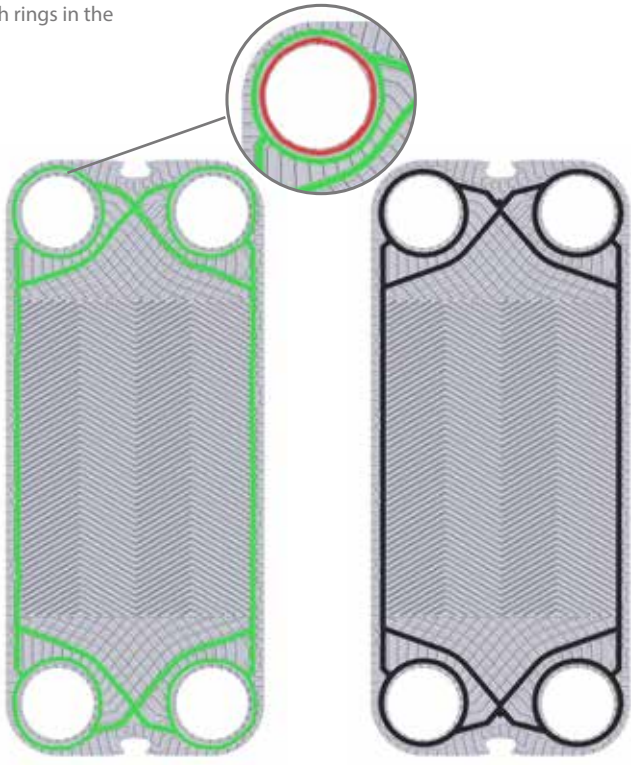

2) Apply a small amount of glue on the green marked area.
If glue reaches the red marked area the start plate can leak.



3) Apply the two gasket halves in the gasket track.

2.6 Plate function

The heat exchanger consists of a pack of corrugated metal plates with port holes for the inlet and outlet of the two separate mediums. The heat transfer takes place through the plates. The plates are fitted with a gasket that seals the channel and directs the fluids into alternate channels. The plate corrugation promotes fluid turbulence and supports the plates against differential pressure.

Our heat exchangers are designed for either single-pass or multi-pass flow, depending on the duty. Single-pass is the preferred solution; as it keeps all connections on the head part, which makes installation cheaper and service easier.

Multi-pass is required when the temperature differences between the flow medium are small. In this case, the connecting piping is on the fixed plate and on the moveable plate.

2.7 Flow arrangement

The heat transfer plates with gaskets are arranged in an alternating pattern, of left-hand flow and right-hand flow, to direct the fluids in an opposing direction within the heat exchanger.

The SonFlow plates are designed to be used as both right and left plates by rotating the plates 180°. Every plate can be recognized by the plate charge number and thermal short or thermal long execution.

When the plate package is pressed together, the portholes form continuous tunnels, leading the media, from the inlets into the plate package, where the media is distributed into the narrow passages between the plates.

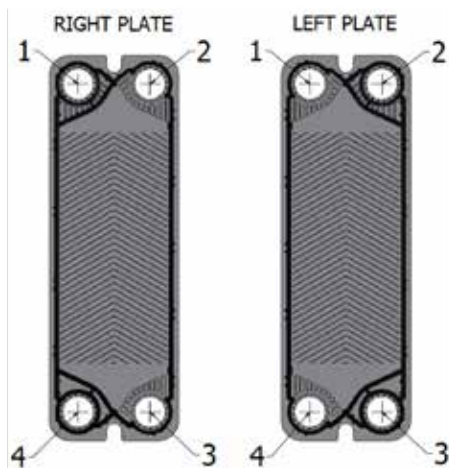

Due to the gasket arrangement on the plates, the two liquids enter alternate passages separated by a thin metal wall.

2.8 Pressure drop

Some pressure drop is unavoidable, however, it should be kept as close as possible to the designed value. A reduced ability to hold the desired temperatures, in combination with increased pressure on the media, indicates fouling or clogging.

2.9 Heat transfer problems

Measure the flow rates and temperatures on both mediums, and check if the amount of heat energy corresponds to the specifications. If the capacity of equipment has dropped below the specified values, the heat exchanger must be inspected and cleaned.

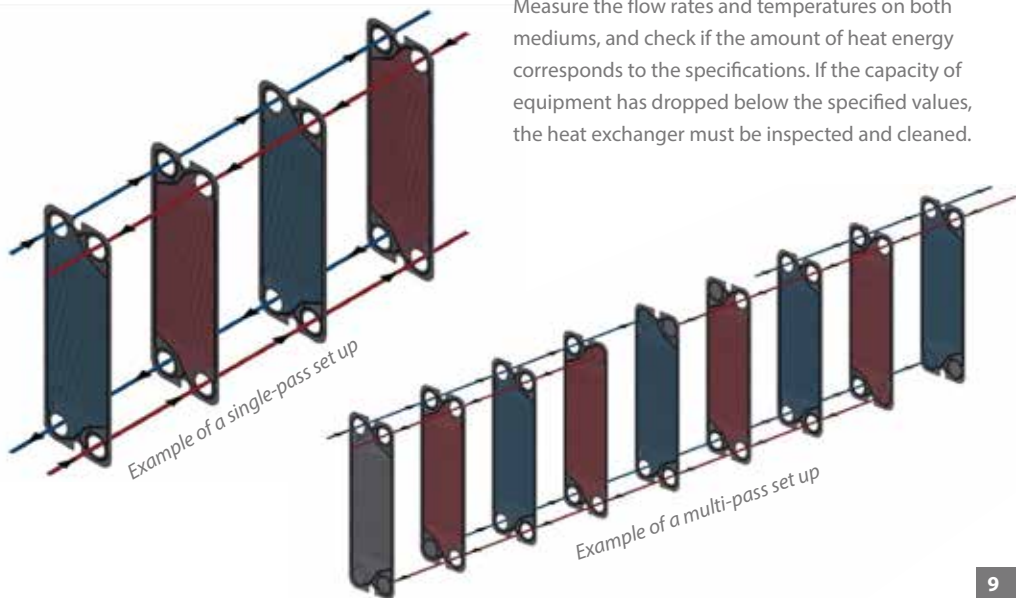

2.10 Removal of plates



Exercise care when handling plates and use protective gloves.



Never open a heat exchanger until the unit has cooled below 40 °C.
Never open a heat exchanger, which is under pressure from any source.
Never open a heat exchanger without dismantling the piping first.

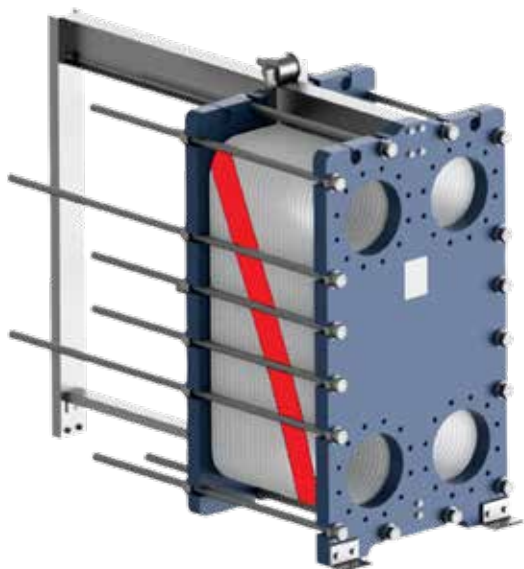

Opening procedure:

- Shut down the heat exchanger
- Close the valves
- Drain the heat exchanger
- Dismantle pipes from the pressure plate
- Inspect the sliding surfaces of the carrying bar
- Mark the plate assembly on the outside by a diagonal line
- Measure and note the dimension
- Remove the locking bolts
- Use the tightening bolts to open the heat exchanger
- Remove the plates one by one, by tilting backwards and then sideways of the carrying bar
- Clean and inspect the plates

Always use correct tightening dimensions, when assembling the heat exchanger.

2.11 Replacing plates

A plate can easily be removed and replaced by a spare plate. When the plates are properly assembled, the edges form a "honeycomb" configuration.

2.12 Cleaning of plates

The SonFlow plates are designed for manual cleaning and cleaning-in-place (CIP) operations. Before disassembly, the user must assure that the unit has

been locked out, de-pressurized, at ambient temperature and drained.

Manual cleaning is normally accomplished by washing the plates with a soft non-metal brush, water and cleaning solution. It is recommended to lay the plate on a flat surface during brush cleaning to avoid the risk of bending the plate.

If the heat exchanger is heavily fouled, care must be taken to remove all debris from the gasket sealing surfaces when the heat exchanger is reassembled.

Manual cleaning of plates:

1. Open the unit (*described in section 2.9*)
2. Clean each plate separately
3. Never use a steel brush or steel wool
4. Do not scratch the gasket surfaces
5. Rinse each plate with clean water (free from salt, Sulphur, chlorine, or high iron concentration)
6. Use high pressure rinse
7. Wipe the gaskets clean or replace it
8. Wipe off the mating surface
9. Inspection and installation of each plate
10. Close the unit

CIP-cleaning (cleaning in place):

A CIP system allows cleaning of the unit without disassembling, which is quick, easy and cost effective. The cleaning is accomplished by circulating a suitable cleaning solution through the heat exchanger instead of opening it. The chemicals used for cleaning must be compatible with materials of construction, while the cleaning solution must be able to dissolve the fouling on the plates.

Cleaning-in-place (CIP):

1. Drain both sides of the unit
2. Flush the unit on both sides with warm water
3. Drain the flush water from the unit and connect CIP pump
4. Rinse with warm water or warm water with softener at maximum flow rate
 - achieve the best cleaning in the reverse direction of normal flow
5. Flush thoroughly with clean water after CIP cleaning

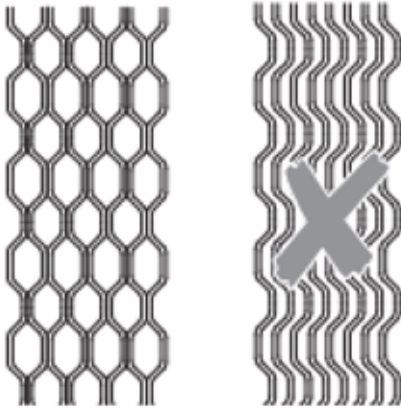

Plate assembly



CAUTION:

Do not use chlorine or chlorinated water to clean stainless steel.

Do not use phosphoric or sulfamic acid for cleaning titanium plates.

Qualified cleaning chemicals:

- Remove oil and grease with a water emulsifying oil solvent
- Remove organic and grease cover with sodium hydroxide (NaOH) maximum concentration 1.5 % - maximum temperature 85 °C. concentration = 5.00 ltr. (30 % NaOH) per 100 ltr. water.
- Remove stone and limestone with nitric acid (HNO₃) - maximum concentration 1.5 % - maximum temperature 65 °C. 1.5 % concentration = 2.4 ltr. (62 % HNO₃) per 100 ltr. water.
- Nitric acid also has an effective build-up effect on the passivation film of stainless steel.

3. Installation

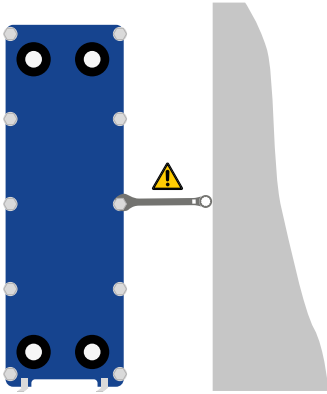

Always place the heat exchanger on a solid foundation floor. Enough space around the unit (1.5 m from the walls), is mandatory when maintaining, renewing plates or tightening the plate package. The authorized personnel are always responsible for the safety, correct selection of lifting equipment and execution of the lifting.

3.1 Lifting

The heat exchanger is supplied horizontally on a pallet, with the back of the head tightened. The heat exchanger can be transported by a forklift.

NOTE: Be careful as the forklift can damage the heat exchanger.

If the weight of the heat exchanger exceeds 3000 kg this option is not available.

Only use straps approved for the weight of the heat exchanger.

SonFlow heat exchangers are provided with holes for safe lifting and transportation. Always observe proper procedures for lifting and/or moving equipment.

When lifting an assembled heat exchanger frame, ensure that the lifting point is above the centre of

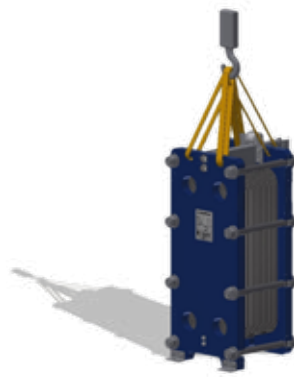

WARNING

To prevent personal injury, use suitable lifting gear.

If you need to lift the heat exchanger, use straps placed as shown in the drawing.

gravity of the equipment. The angle should not exceed 120°C at any time.

Carefully follow the instructions below:

- Remove all tightening elements from the pallet
- Place straps around one bolt on each side (never use steel cables or chains!)
- Lift the heat exchanger
- Lower the heat exchanger slowly to vertical
- Remove the straps and tighten the unit to the floor



REMEMBER:

- Use the lifting eyes (when lifted)
- Lift the top side
- Attach the straps to the bolts by the head



NEVER:

- Lift by the connections
- Lift the moveable plate
- Lift with a strap attached to the moveable plate

3.2 Raising

This instruction is valid when raising the heat exchanger after delivery from SonFlow. Only use straps approved for the weight of the heat exchanger. The straps shall be long enough for the heat exchanger to rotate.

Follow the principles:

1



Remove the support feet and place two timber beams on the floor

2



Lift the heat exchanger off the pallet by using straps

3

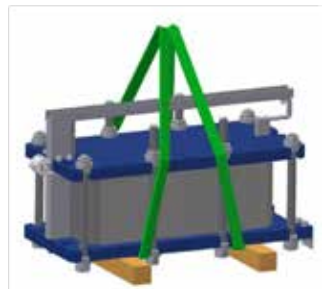

Place the heat exchanger on the timber beams

4



Place straps around the heat exchanger

5

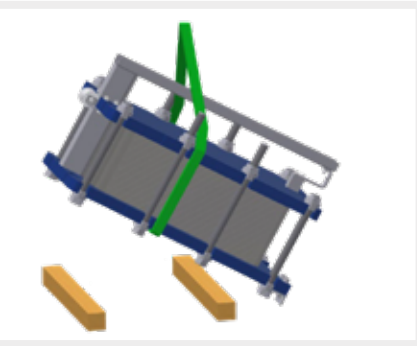

Lift the heat exchanger from the timber beams

6



Lower the heat exchanger to horizontal and place it on the floor

3.3 Connections

If the heat exchanger has connections on the moveable plate, the compressed dimension must be checked against the drawing before the pipes are connected. It is necessary to leave free space around the equipment to give access and make future service possible. The dimensions suggested are 1.5 m to provide reasonably good working conditions during installation as well as maintenance and service.

3.4 Installing the pipe connections

Flanges, couplings, threaded pipes etc. will be equipped according to the type of SonFlow heat exchanger.

Our advice:

- Support the heavy pipework, that will prevent heavy forces on the heat exchanger
- To prevent vibrations always install flexible connections on the moveable plate, which also will prevent the expansion of the pipework caused by temperature influence – must be fitted in a longitudinal direction to the plate package
- Before connecting to the heat exchanger, always remember to thoroughly clean the pipework
- Vents must be installed on both sides of the heat exchanger

NOTE:

Vents should be fitted on the highest point in the direction of the flow of the medium. Shut off valves in all connections when opening the heat exchanger.

Threaded pipe connections

If a threaded pipe connection is provided, connections may not rotate when fitting to the pipework, as it could damage the gasket on the start plate.

Flange connections

If the connection is rubber lined, the liner will act as

the flange gasket. The connecting flange must be bolted directly to the endplate by using the drilled and tapped holes. Bolts must be tightened evenly (do not overtighten!).

Unless otherwise stated, the liquid circuits should be connected to flow in reverse directions through the exchanger (counter-current).

3.5 Storage

Certain precautions are necessary when storing the heat exchanger for a longer period (1 month or more). The heat exchanger should be stored indoors with a temperature of 15 to 20 °C and humidity of max. 70 %.

The heat exchanger can also be stored in a wooden box provided with a lining on the side against penetration of moisture. It must be protected from water, debris and sunlight, while also allowing air circulation.

Ozone producing equipment in the storage room is prohibited due to the destruction of rubber materials, such as operating electric motors or welding equipment. Do not store organic solvents or acids in the room and avoid heat or ultraviolet radiation.

All connections must be closed to prevent water or debris to enter the heat exchanger. Plugs or covers may be used.

3.6 Start-up

Before start-up, check that all tightening bolts are firmly tightened and the plate pack has correct measurements.

Starting-up the heat exchanger must be initiated slowly and smoothly to avoid any pressure shocks/water hammering which might damage the equipment or cause leakage:

- Make sure the plate pack is compressed to the right measurements

- Avoid extreme variations of temperature and pressure to avoid damages
- Before starting any pump, check instructions and check the valve between the pump and the equipment controlling the flow rate of the system
- The valve at the exit should be fully open – if there is one
- Open the vent
- Start the pump
- Open the valve slowly
- When all air is out, close the vent
- Repeat the procedure for the other media
- Design pressures and temperatures for each model are marked on the nameplate, which shall not be exceeded

Take protective actions to avoid risk for material- and personnel injuries. Always ensure that the required actions are according to local regulations.

4. Commissioning

Commissioning may only be executed by trained staff or by SonFlow commissioning engineers.

Maintenance, repair and control of the unit may only be executed by authorized and trained staff.

Maintenance and cleaning may only be executed when the temperature of the heat exchanger is below 40°C and shut down.



If you use hazardous flow media (e.g. explosive, flammable, caustic, toxic, under high pressure, very hot or very cold) persons can get in contact with the flow medium and become injured if the heat exchanger is leaky.

- That no residues are present inside the heat exchanger

Operating conditions:

- Avoid liquid hammers
- Make sure that the heat exchanger is not operated with unpermitted flow media, pressure or temperature levels
- Ensure that the heat exchanger is vented

Filtration

Filtration prevents foreign particles with a potential risk of disrupting the performance of the system. The filter prevents particles from flowing through the heat exchanger and cause clogging of the heat exchanger.

4.1 Operation

Always start with the cold circuit, afterwards the hot circuit.

Fully vent the system:

Before starting the heat exchanger commissioning, follow the conditions below:

- That all components have been completely installed
- All piping connections are firmly connected
- Tensioning dimension of the heat exchanger pack is within the permitted value range

- Close and shut off the valve fitted between the pump and exchanger
- Fully open the valve fitted into the return line from the exchanger

- Start the circulation of the pump normally when placed by the inlet
- Gradually open the closed and shut off valve between the pump and exchanger
- Vent system again if necessary

Repeat the above for the secondary circuit.

Steam as the media

Slowly use acting steam control valves and slowly open the shut-off valves.

Before starting:

- Ensure that the steam control valve is fully closed
- Ensure that the heat exchanger is fully drained of condensate
- Start cold circuit first, then the steam
- Slowly open the steam control valve – prevents thermal shock to the exchanger
- Ensure that the steam trap is correctly sized to allow condensate discharge, which prevents water from clogging

Check for proper operation:

- Check for pressure pulses in the system caused by the pumps or control valves. Stop operation and rectify if found
- Check the unit for leakages
- Check that all the vents are closed to prevent air from being sucked inside.

4.2 Shut down for a short period

Follow the following procedure:

- Close the control valve in the hot circuit and maintain the full flow in the cold circuit
- Turn off the hot circuit pump
- The heat exchanger must cool down
- Close the control valve in the cold circuit
- Turn off the cold circuit pump
- Close all remaining shut off valves

4.3 Shut down for a long period

If the unit must be disconnected, follow the following procedures:

- Never open a heat exchanger unit when it is hot – the heat exchanger must cool down
- Decrease the pressure of both fluids
- Completely drain fluids from the unit
- Lubricate all bolts
- Loosen the clamping bolts until the plate pack is loosened
- Do not remove tie bolts
- Cover the plate pack to avoid sunlight

(Described in section 3.5)

5. Maintenance



Never open a heat exchanger until the unit has cooled below 40 °C.

Never open a heat exchanger, which is under pressure from any source.

Never open a heat exchanger without dismantling the piping first.

SonFlow recommends maintenance once a year as a minimum to keep the heat exchanger in good condition.

The plates must be cleaned regularly depending on the type of media and temperature. After a long period of use, it can be required to regasket the heat exchanger.

What should be performed regularly:

- Lubricate the carrying bar and guiding bar
- Lubricate bolts
- Check temperatures and flows
- Check general condition
- Look for signs of leakage
- Look for signs of damage
- Check bolts and bars for rust

(Described in section 2.9 - removal of plates)

For large units, block the moveable plate into position, by tying it to the end support, to provide extra safety against accidental rolling of the moveable plate during maintenance.



Always wear protective gloves when handling plates.

5.1 Frame maintenance

Carry out simple maintenance work of the frame:

- Clean the outside of the heat exchanger frame, especially the beams, rails and bars
- Grease the guide rails
- Rework paint damage

5.2 Pressure test after maintenance

These processes are only allowed to be performed by a person authorized according to local laws and regulations and following applicable standards.

It is recommended to perform a pressure test to confirm the internal and external sealing function of the heat exchanger.

Test pressure is stated on the nameplate - the pressure test shall be performed at equal pressure, never above the design pressure.

In a multi-section setup, all sections of the same side must be tested simultaneously.

Test time: 10 minutes

If the unit is leaking, it may be tightened step by step according to the dimensions, which are mentioned on the nameplate.

Rebuilding or modification of the heat exchanger is the responsibility of the end-user.

6. Problem Solving

In most cases, problems can be solved by your own personnel when it comes to:

Leakage:

- At the connections – check the rubber liners, check the flange gasket, check the O-ring and fit the pipes tension-free
- Mixing of a primary and secondary circuit – check the plates for holes and cracks
- Plate package – check the assembly, check the condition of the gaskets, check the proper position of the gasket
- Tighten the plate package step by step according to the dimensions, which are mentioned on the nameplate
- The operating conditions – adjust the operating conditions

Insufficient capacity:

- Air in the system – de-aerate the pipe system and check the pipework for possible air traps

- Conditions deviate from the specification – adjust the operating conditions
- A dirty heat exchanger – clean the heat exchanger
- Connections have been interchanged – do the pipework again

Too high-pressure drops:

- Flow larger than the design flow – adjust the flow
- Channels blocked in the plates – flush/clean
- Incorrect measurements – check the pressure indicator
- Medium deviating from the design – anti-freeze will increase the pressure drop
- Air in the system – de-aerate the pipe system and check the pipework for possible air traps

7. After-Sales & Service

When ordering parts, the following should be quoted:

- Exchanger type and manufacturing number
- Required parts
- Plate types
- Gasket material

We are globally active, therefore, not far away to support you and obtain the maximum availability of your systems. We aim to ensure high-quality spare parts for the trouble-free operation of your heat exchanger. We are always happy to answer any questions you may have and meet your requirements. We look forward to hearing from you.

About SonFlow A/S

DanPumps A/S changed its company name to SonFlow A/S in 2019 and started manufacturing plate heat exchangers - it signals new investments and new missions as we want to focus on process technology, energy and the environment. SonFlow A/S works hard to ensure the philosophy of innovation and advancement by delivering best in quality products and good service.

We strive our best to safeguard the environmental processes and adapt modern friendly approaches in product design and production processes. DanPumps centrifugal pumps are still being marketed under the brand name DanPumps.



Plate heat exchangers as a complementary product

SonFlow A/S offers plate heat exchangers as a complementary product to DanPumps centrifugal pumps, which opens new markets. The engineering team of SonFlow is developing new designs and customized process equipment's based on many years of experience.

We are ISO 9001 certified and provide plate heat exchangers and pumps to all industries - we are continually expanding and diversify the business responding with innovative high-quality products and services.

Manufacture of plate heat exchangers and pumps

SonFlow A/S is specialized in manufacturing centrifugal pumps within all industries and plate heat exchangers to use in thermal processes.

SonFlow offers a broad range of products for different applications - you can rely on SonFlow specialists to take a professional approach to your specific challenge and solve difficult pumping and plate heat exchanger applications.



Aage Søndergaard Nielsen
Founder & CEO